

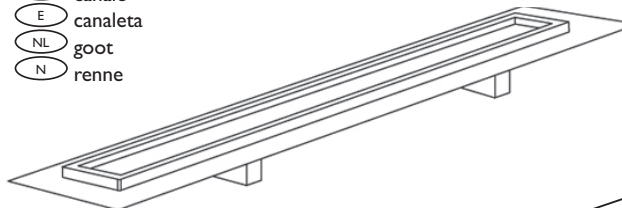

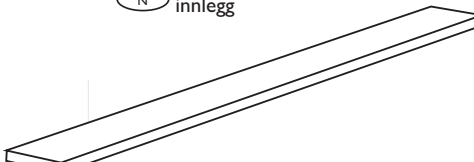
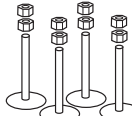
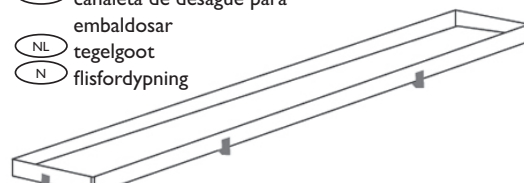
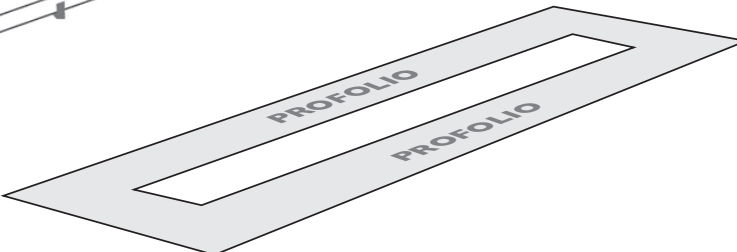

## PROCHANNELp-line

### Produkt & Zubehör

GB product & accessories    F produit & accessoires    I prodotto & accessorio    E producto & accesorios    NL product & bijbehorend materiaal    N produkt & tilbehør

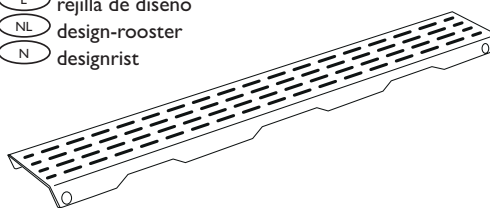
<p><b>PROCHANNELp-line Rinne</b></p> <ul style="list-style-type: none"> <li><span>GB</span> channel</li> <li><span>F</span> caniveau</li> <li><span>I</span> canale</li> <li><span>E</span> canaleta</li> <li><span>NL</span> goot</li> <li><span>N</span> renne</li> </ul> 	<p><b>PROCHANNELp-line Schaum-Schutzeinlage</b></p> <ul style="list-style-type: none"> <li><span>GB</span> insert</li> <li><span>F</span> insert</li> <li><span>I</span> intercapedine</li> <li><span>E</span> capa intermedia</li> <li><span>NL</span> inlage</li> <li><span>N</span> innlegg</li> </ul> 	<p><b>PROCHANNEL Montagefüße</b></p> <ul style="list-style-type: none"> <li><span>GB</span> mounting feet</li> <li><span>F</span> pieds de montage</li> <li><span>I</span> piedini di montaggio</li> <li><span>E</span> pie de montage</li> <li><span>NL</span> montagevoet</li> <li><span>N</span> monteringsfotter</li> </ul> 
<p><b>PROCHANNEL Fliesenmulde</b></p> <ul style="list-style-type: none"> <li><span>GB</span> tiled basin</li> <li><span>F</span> cache en carrelage</li> <li><span>I</span> canalina pavimento</li> <li><span>E</span> canaleta de desagüe para embaldosar</li> <li><span>NL</span> tegelgoot</li> <li><span>N</span> flisfordypning</li> </ul> 	<p><b>PROCHANNELp-line Dichtmanschette</b></p> <ul style="list-style-type: none"> <li><span>GB</span> sealing sleeve</li> <li><span>F</span> manchon d'étanchéité</li> <li><span>I</span> fascetta impermeabile</li> <li><span>E</span> anillo de junta impermeabilizante</li> <li><span>NL</span> afdichtmanchet</li> <li><span>N</span> tetningsmansjett</li> </ul> 	<p><b>PROCHANNEL Schallschutzpads</b></p> <ul style="list-style-type: none"> <li><span>GB</span> pads</li> <li><span>F</span> tampons</li> <li><span>I</span> cuscinetti</li> <li><span>E</span> tampones</li> <li><span>NL</span> pads</li> <li><span>N</span> puter</li> </ul> 
<p><b>PROCHANNEL Designrost</b></p> <ul style="list-style-type: none"> <li><span>GB</span> design plate</li> <li><span>F</span> grille design</li> <li><span>I</span> grata design</li> <li><span>E</span> rejilla de diseño</li> <li><span>NL</span> design-rooster</li> <li><span>N</span> designrist</li> </ul> 	<p><b>PROCHANNEL Geruchsverschluss</b></p> <ul style="list-style-type: none"> <li><span>GB</span> odour trap</li> <li><span>F</span> coupe-odeur</li> <li><span>I</span> sifone intercettatore</li> <li><span>E</span> sifón</li> <li><span>NL</span> zwanehals</li> <li><span>N</span> vannlås</li> </ul> 	<p><b>PROCHANNEL Ablauftöpfe</b></p> <ul style="list-style-type: none"> <li><span>GB</span> drainage pots</li> <li><span>F</span> siphons</li> <li><span>I</span> sifoni doccia</li> <li><span>E</span> cazoletas sifónicas</li> <li><span>NL</span> afvoerbakken</li> <li><span>N</span> avløpsgrytter</li> </ul> 

### Werkzeug

GB tools    F outils    I arnese    E herramienta    NL gereedschappen    N verktøy

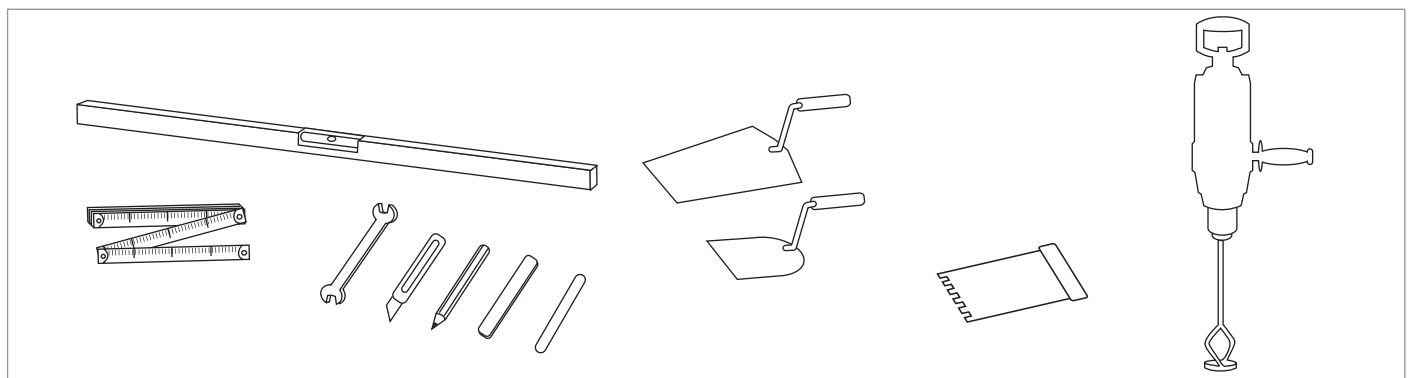

# PROCHANNELp-line

## Hilfsstoffe

GB supplies    F matières auxiliaires    I materia sussidiaria    E materiales adicionales    NL hulpmiddelen    N ekstra utstyr



### PROFIX DS Dichtschlämme

- GB sealing gels
- F enduit ,étanchéité
- I Fanghi isolanti
- E Lechada de impermeabilización
- NL afdichtmortel
- N Tetningsslam

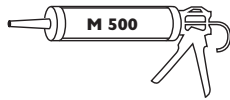

### Ottocoli M500 Hybrid-Kleb- und Dichtstoff

- GB hybrid adhesive and sealant
- F matière adhésive et d'étanchéité hybride
- I Colla sigillante ibrida
- E Adhesivo híbrido y compuesto sellante
- NL hybride lijm en afdichtmiddel
- N Hybrid klebe- og tetningsmaterial

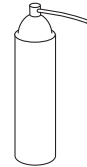

### 2K-Montageschaum

- GB 2.component mounting foam
- F mousse de montage à 2 composants
- I schiuma di montaggio 2K
- E espuma de montaje 2K
- NL 2K-montageschuim
- N 2K-monteringskum



### Styroporgranulat

- GB polystyrene granulate
- F granulés de polystyrène
- I granulato polistirolo
- E granulado de poliestireno
- NL styroporgranulaat
- N styroporgranulat

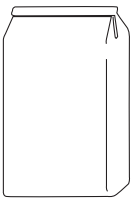

### Estrichmörtel

- GB screed mortar
- F mortier de chape
- I massetto con malta
- E mortero de solado
- NL afwerkvloermortel
- N sementmørtel



### zementärer Dünnbettmörtel

- GB cement-based thin-bed mortar
- F mortier colle ciment
- I malta cementosa a letto sottile
- E mortero a base de cemento para lecho fino
- NL gecemt dunbedmortel
- N sementert tynnsengmørtel

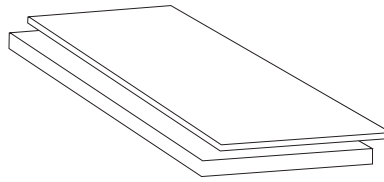

### Dämmstoffplatten

- GB insulation boards
- F panneaux isolants
- I pannelli isolanti
- E planchas aislantes
- NL isolatieplaten
- N demmematerialplater

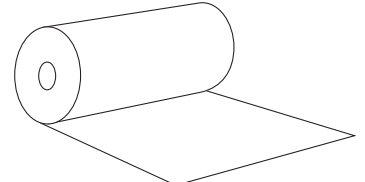

### PROBASE Aqua-Stop PE 200µm Dampfbremsfolie

- GB vapour-barrier film
- F feuille pare-vapeur
- I foglio isolante con barriera al vapore
- E lámina cortavapor
- NL tape en ontvettende reiniger
- N dampbremsefolie

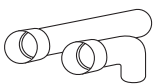

### Muffenrohre

- GB socket pipe
- F tuyaux à manchons
- I tubi a bicchiere
- E tubos de manguito
- NL moffenbuis
- N mufferør

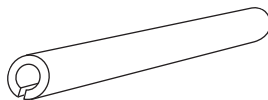

### Schutzschlauch

- GB protective tube
- F tuyau de protection
- I tubo flessibile di protezione
- E tubo flexible de protección
- NL bescherm slang
- N verneslange



### PROSTRIP L Randdämmstreifen

- GB edging strip
- F bandes périphériques
- I strisce isolanti per bordi
- E bandas de aislamiento para bordes
- NL randisolatiestroken
- N kantdemmestriper

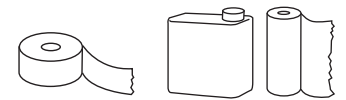

### Klebeband und entfettender Reiniger

(Sicherheitsmaßnahmen entsprechend Herstellerangaben beachten.)

- GB Adhesive tape and degreasing cleaner. (Observe safety measures according to manufacturer's specifications.)

- F Ruban adhésif et nettoyant dégraissant. (Respecter les mesures de sécurité selon les instructions du fabricant.)

- I Nastro adesivo e detergente sgrassante. (Attenersi alle avvertenze di sicurezza indicate dal produttore.)

- E Cinta adhesiva y limpiador desengrasante. (Tenga en cuenta las medidas de seguridad del fabricante.)

- NL Tape en ontvettende reiniger. (Neem de veiligheidsmaatregelen volgens de fabrieks-aanwijzingen in acht.)

- N Klebeband og avfettende rengjøringsmiddel. (Ta hensyn til sikkerhetstiltakene iht. informasjonene fra produsenten.)

# PROCHANNELp-line

## mit Dämmstoffen

GB with insulation materials    F avec matériaux isolants    I con isolanti    E con materiales de aislamiento    NL met isolatiemateriaal    N med demmematerialer

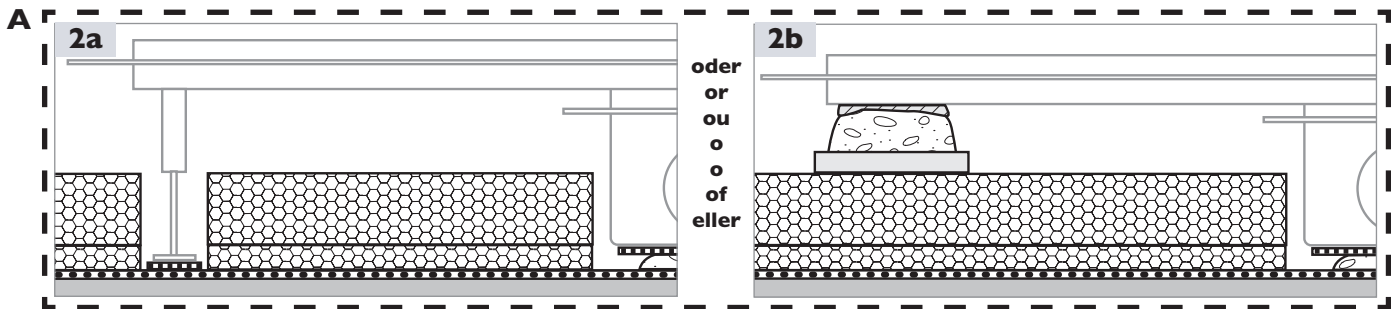
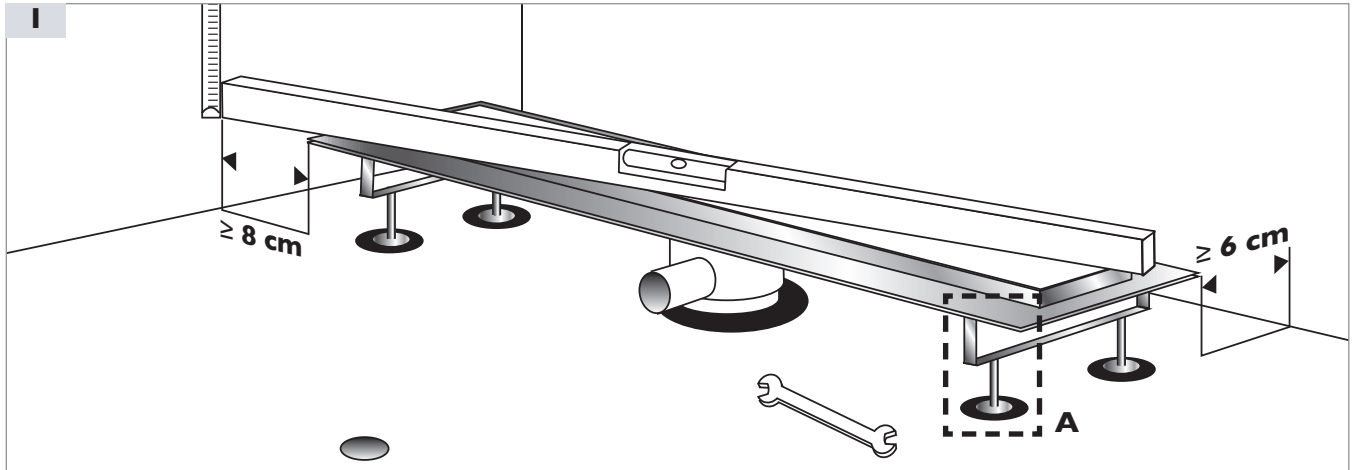

### Maße

GB dimensions    F dimensions    I misure  
E medidas    NL afmetingen    N mål

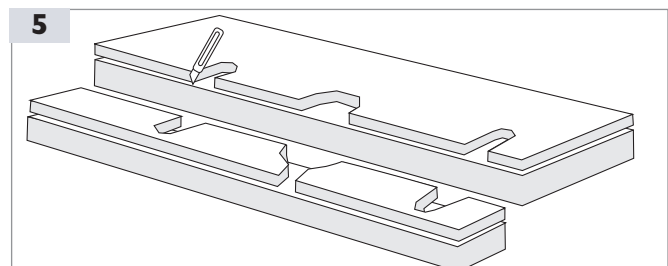
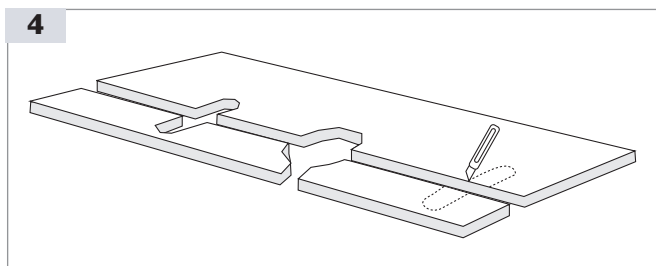
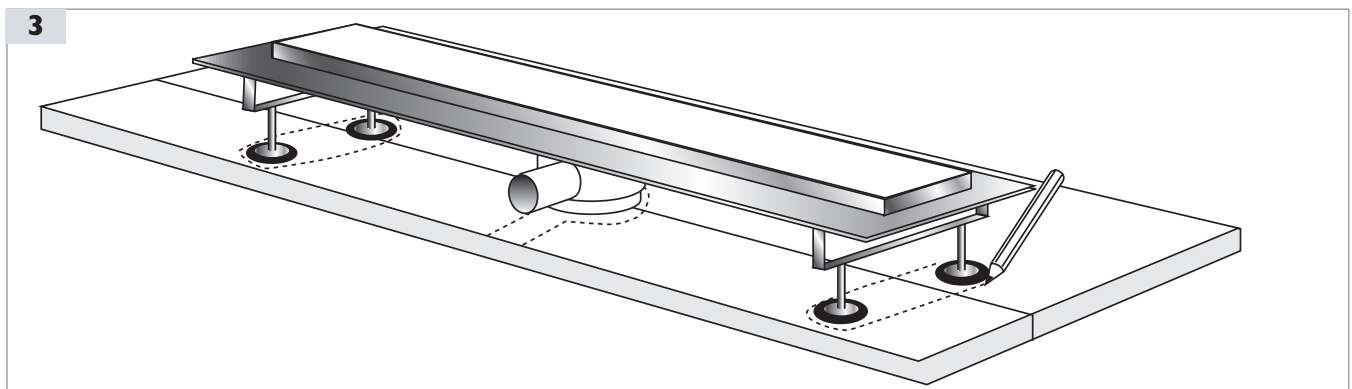

AUSGABE\_2014\_01\_LIZ\_AH

# PROCHANNELp-line

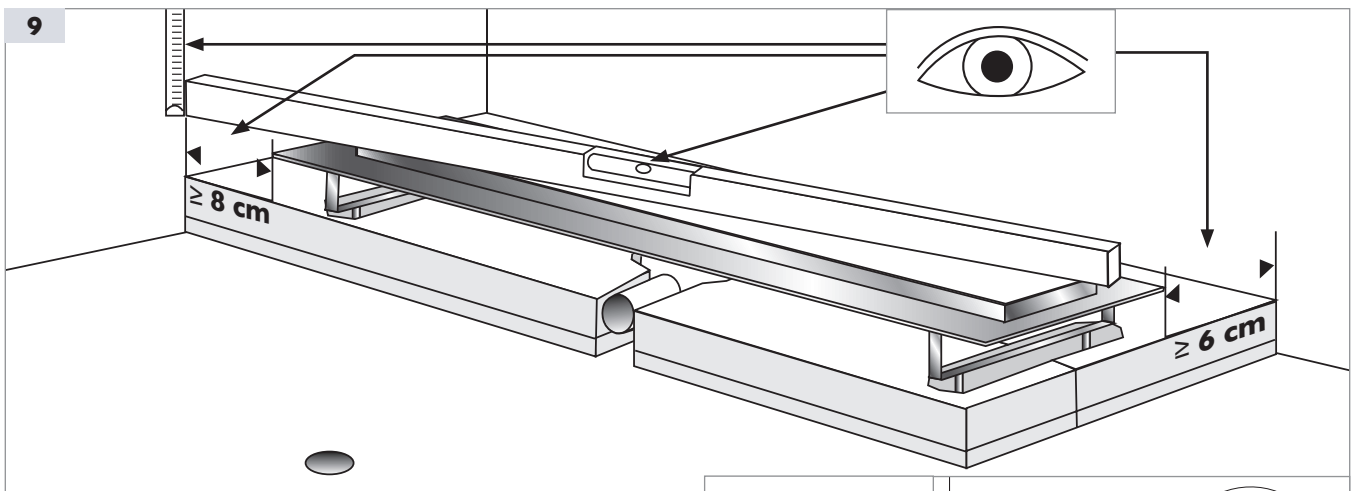
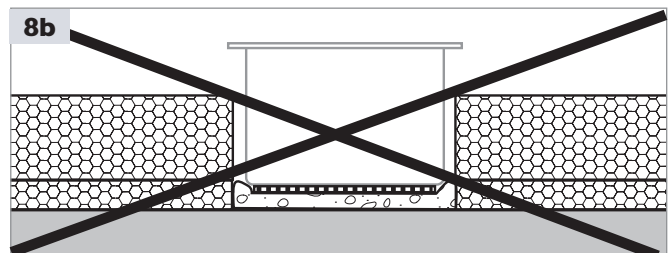
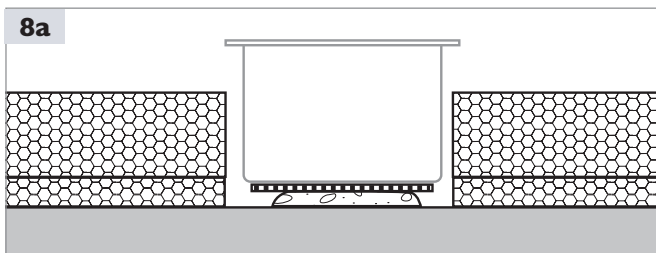
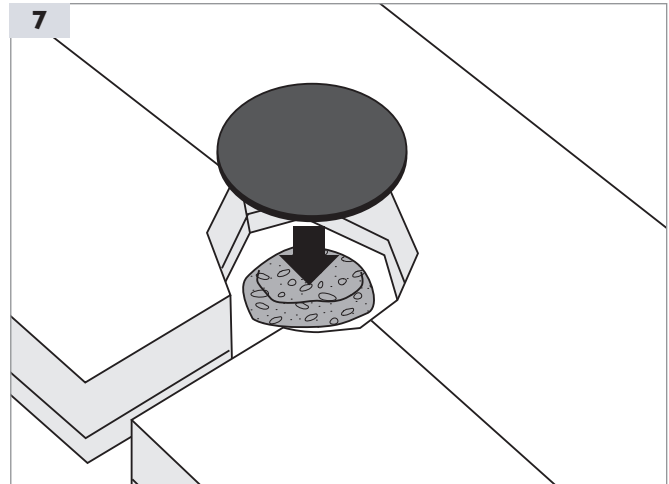
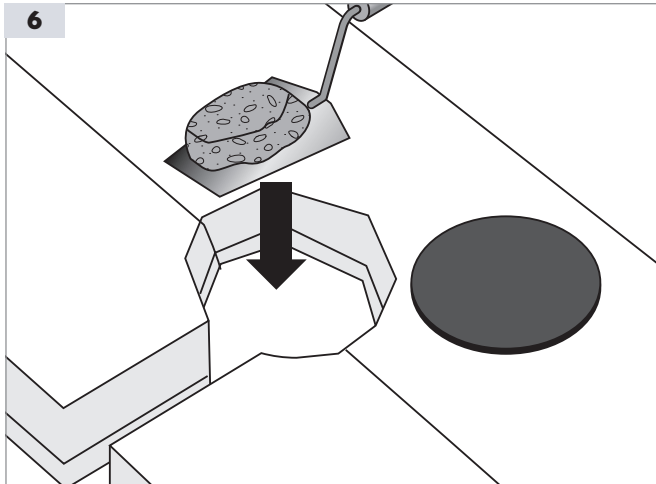

**Maße**

- |               |               |          |
|---------------|---------------|----------|
| GB dimensions | F dimensions  | I misure |
| E medidas     | NL afmetingen | N mål    |

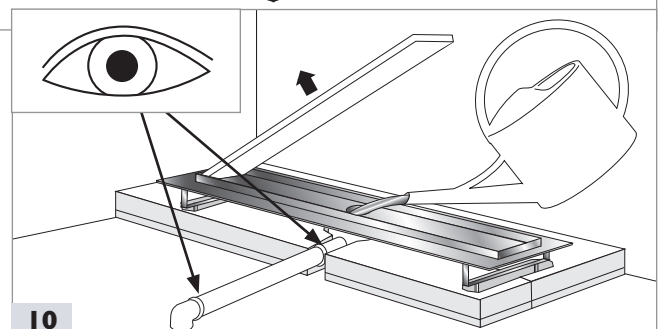

# PROCHANNELp-line

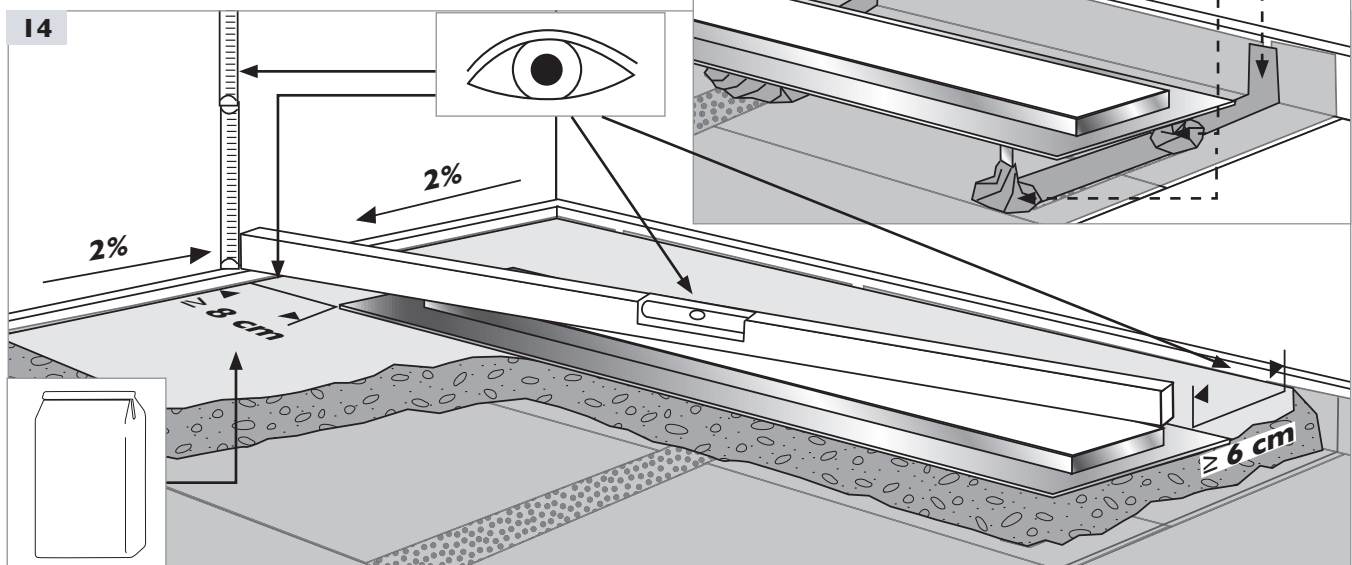
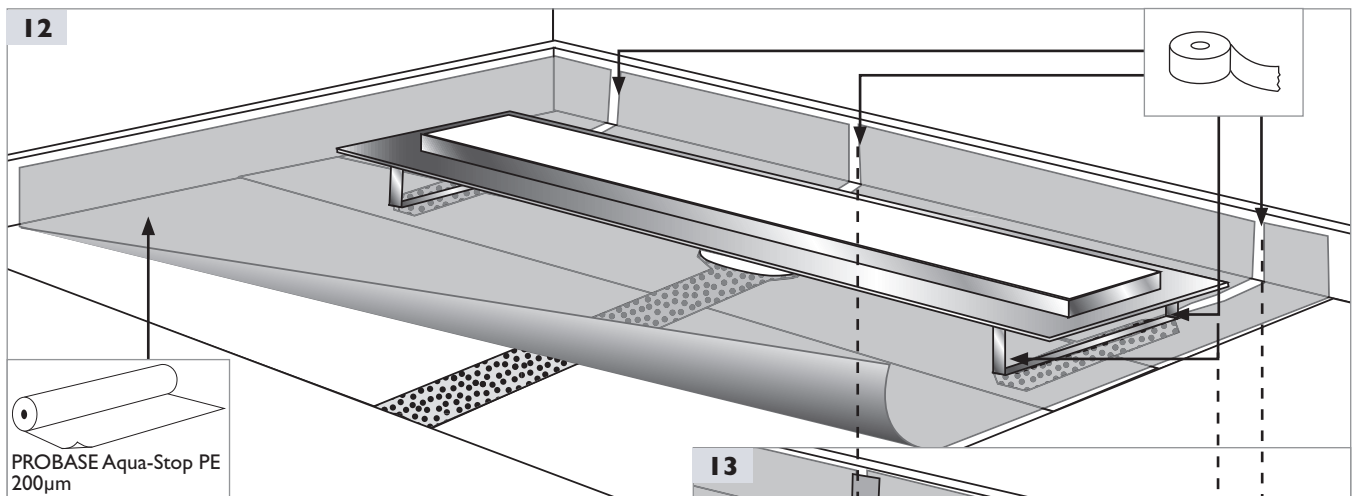
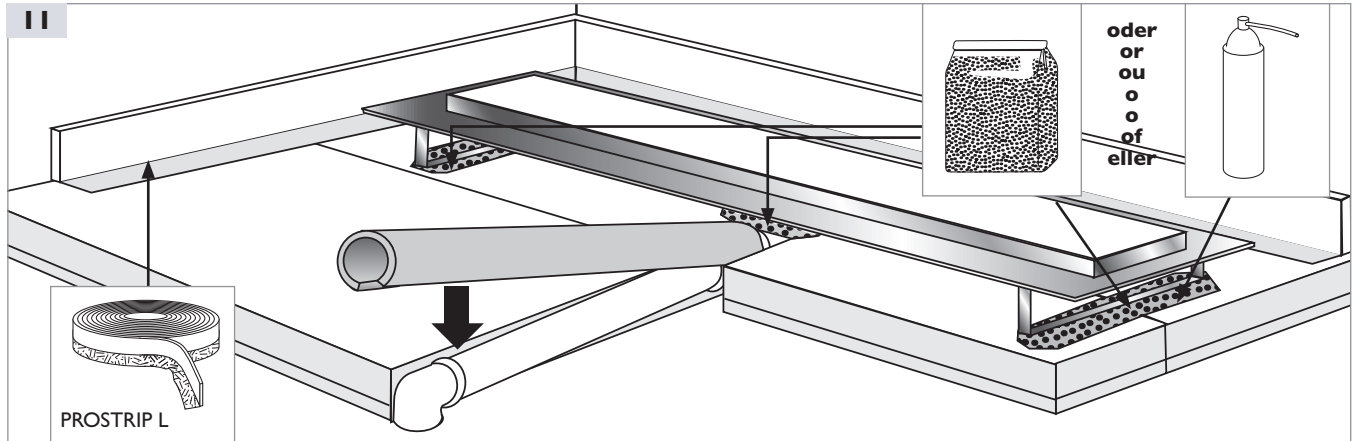

AUSGABE\_2014\_01\_LIZ\_AH



# PROCHANNELp-line

## ohne Dämmstoffe

GB without insulation materials    F sans matériau isolant    I senza isolanti    E sin materiales de aislamiento    NL zonder isolatiemateriaal    N uten demmematerial

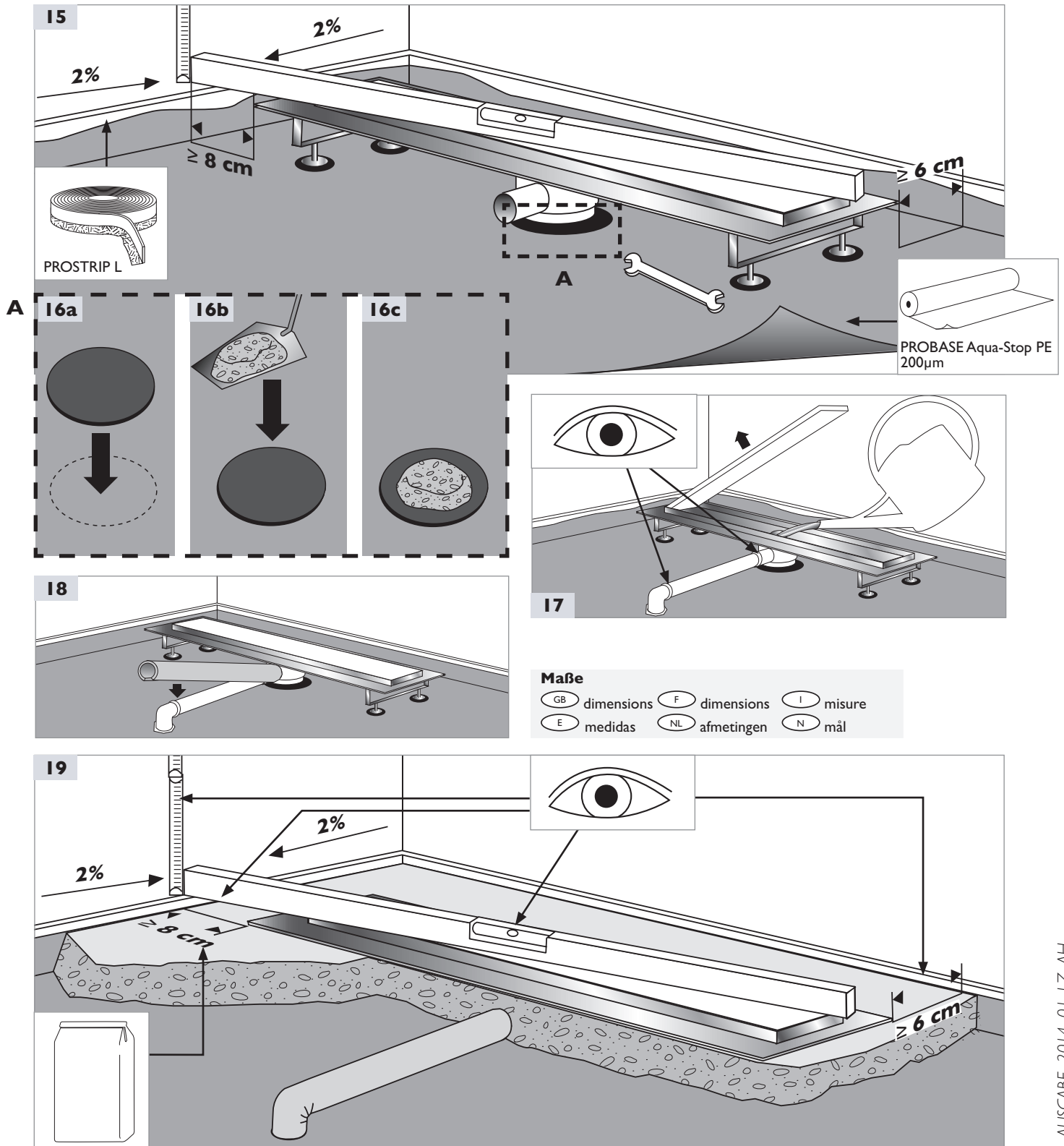

AUSGABE\_2014\_01\_LZ\_AH

# PROCHANNELp-line

## Senkrecht-Ablauf

Die Machbarkeit einer Kernbohrung durch eine Geschossdecke ist von geeignetem Fachpersonal aus statischer und brandschutztechnischer Sicht zu prüfen und zu genehmigen.

- GB vertical drainage pot    The feasibility of core drilling through a ceiling must be reviewed and approved by suitable trained personnel from a structural and fire prevention standpoint.
- F siphon vertical    La faisabilité d'un carottage à travers un plafond doit être vérifiée et autorisée par du personnel qualifié pour des raisons inhérentes à la statique et à la protection contre les incendies.
- I sifone doccia verticale    La fattibilità di un carotaggio attraverso un soffitto deve essere verificata e approvata dal punto di vista statico e della protezione antincendio da parte di personale specializzato.
- E cazoleta sifónica vertical    La viabilidad de una perforación en un techo debe comprobarla y autorizarla únicamente personal técnico cualificado teniendo en cuenta las propiedades estáticas y las medidas de protección contra incendios.
- NL verticale afvoerbak    De haalbaarheid van een kernboorgat door een verdieplingsplafond moet door geschikt vakpersoneel vanuit statisch en brandtechnisch oogpunt worden gecontroleerd en goedgekeurd.
- N vertikalt avløpsgrøt    Egnert fagpersonnal må kontrollere og godkjenne om det ut i fra statisk og brannteknisk sikt er mulig å gjennomføre en kjerneboring gjennom taket.

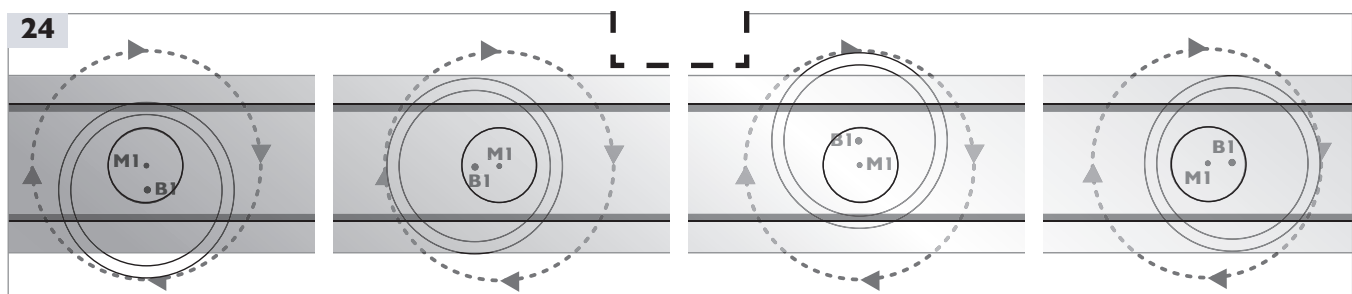
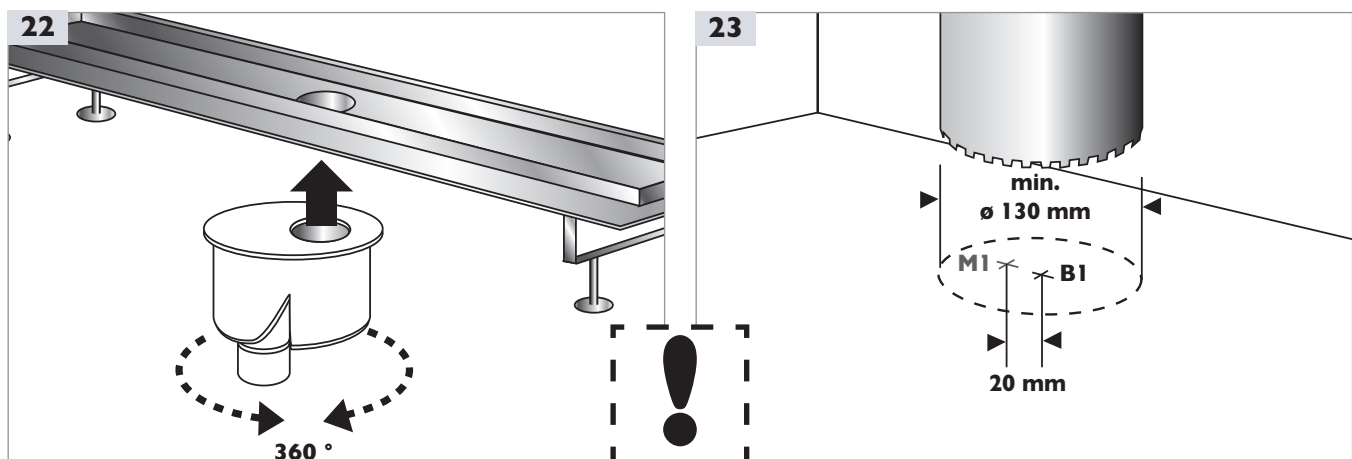
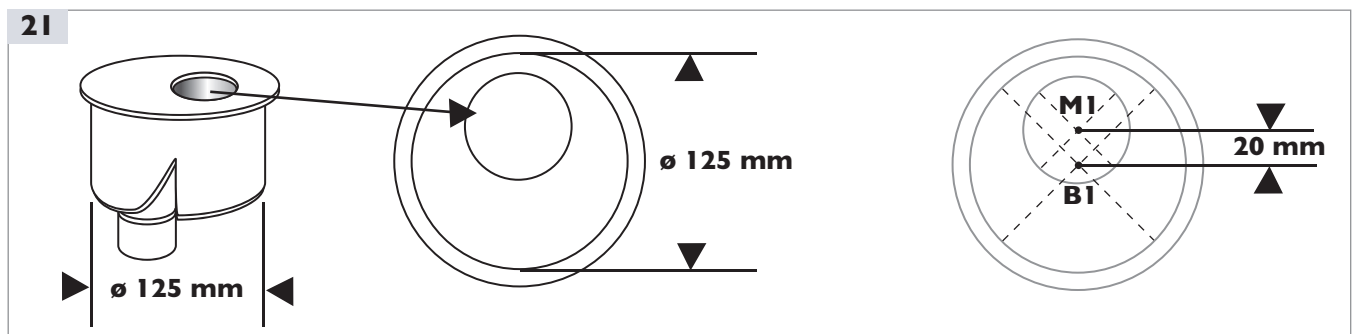
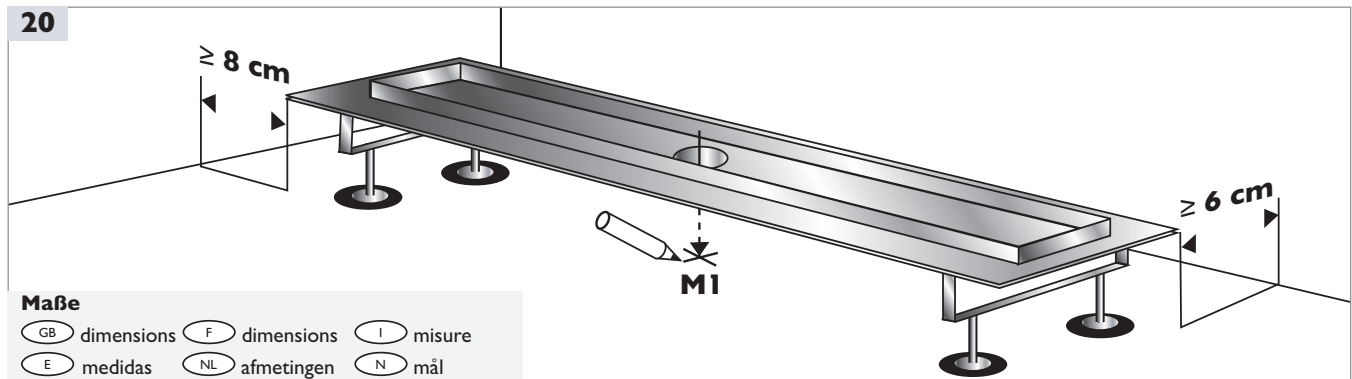

AUSGABE\_2014\_01\_LIZ\_AH

# PROCHANNELp-line

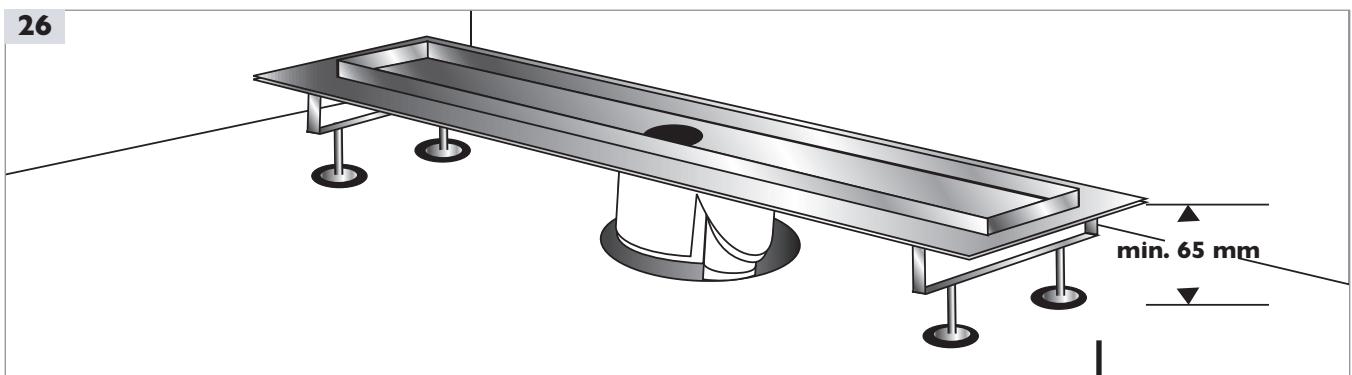
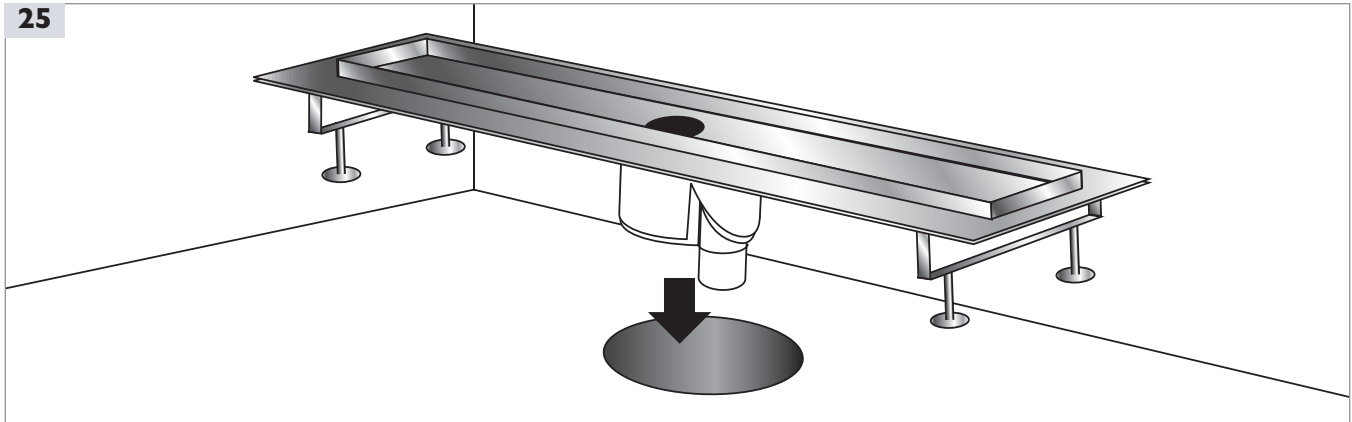

15  
19



# PROCHANNELp-line

## Dichtmanschette

GB sealing sleeve    F Manchon d'étanchéité    I Fascetta impermeabile    E anillo de junta impermeabilizante    NL Afdichtmanchet    N Tetningsmansjett

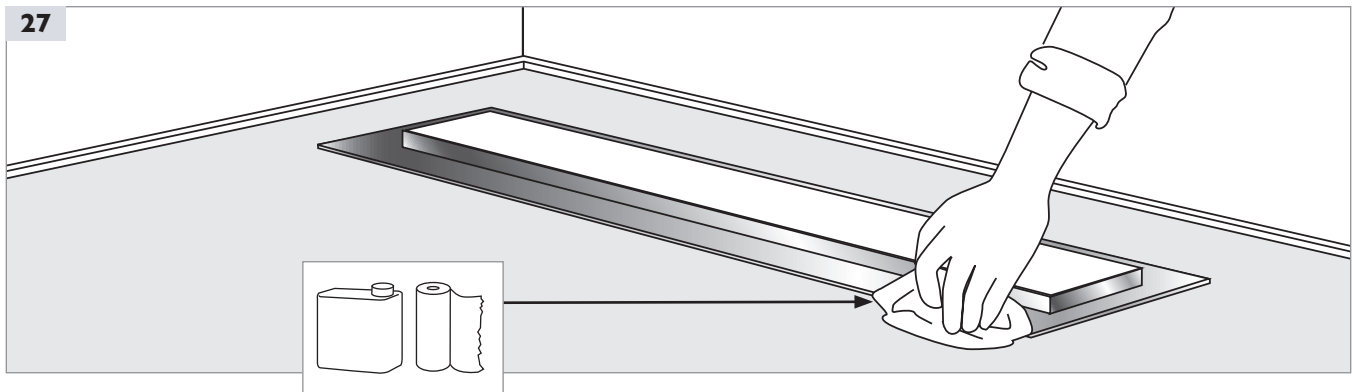

**Maße**

GB dimensions    F dimensions    I misure  
E medidas    NL afmetingen    N mål

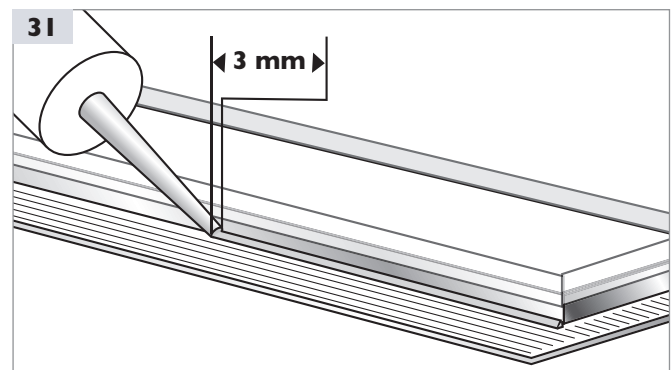
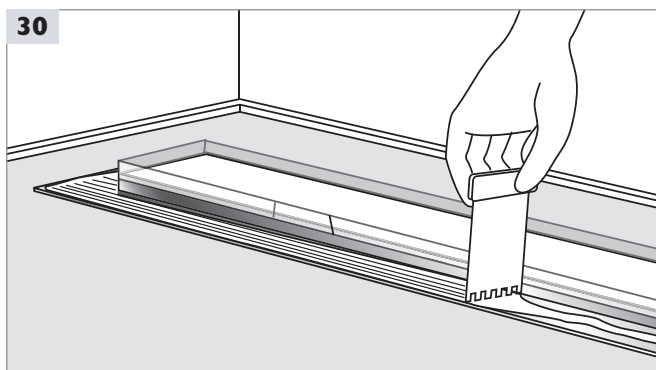
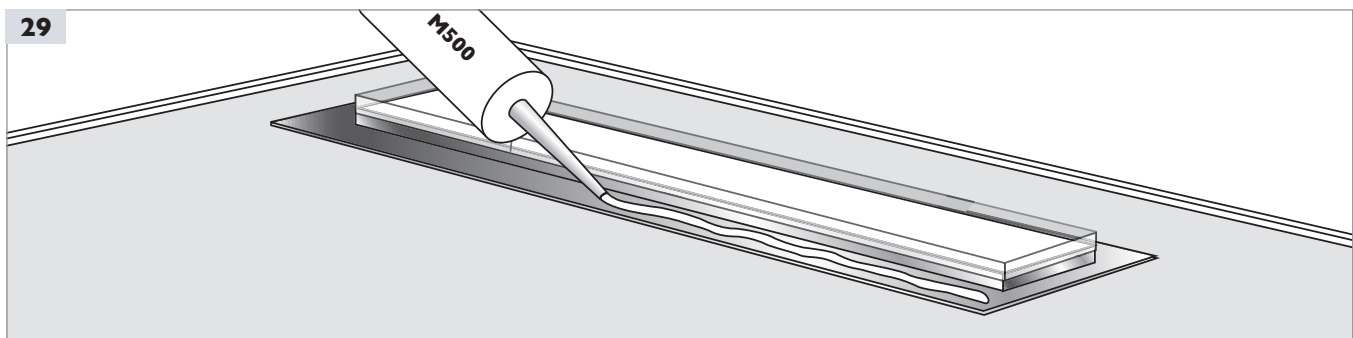
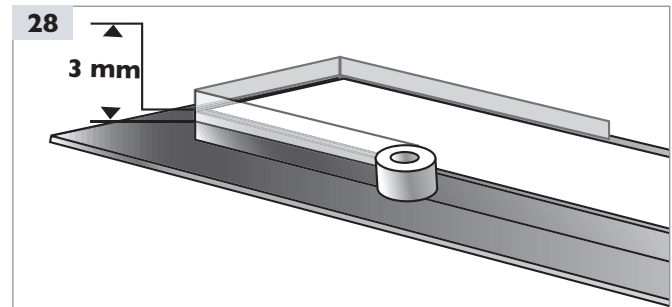

**Maße**

GB dimensions    F dimensions    I misure  
E medidas    NL afmetingen    N mål

AUSGABE\_2014\_01\_LIZ\_AH

# PROCHANNELp-line

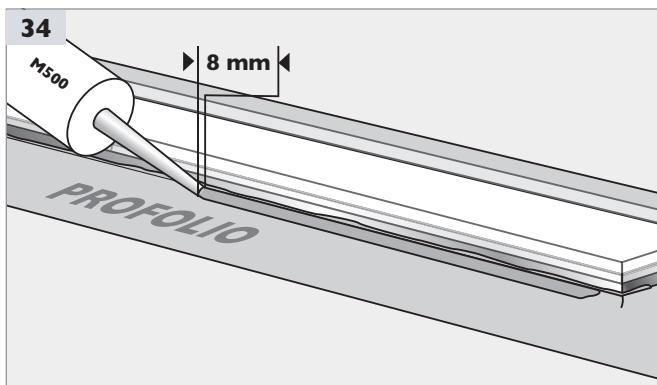
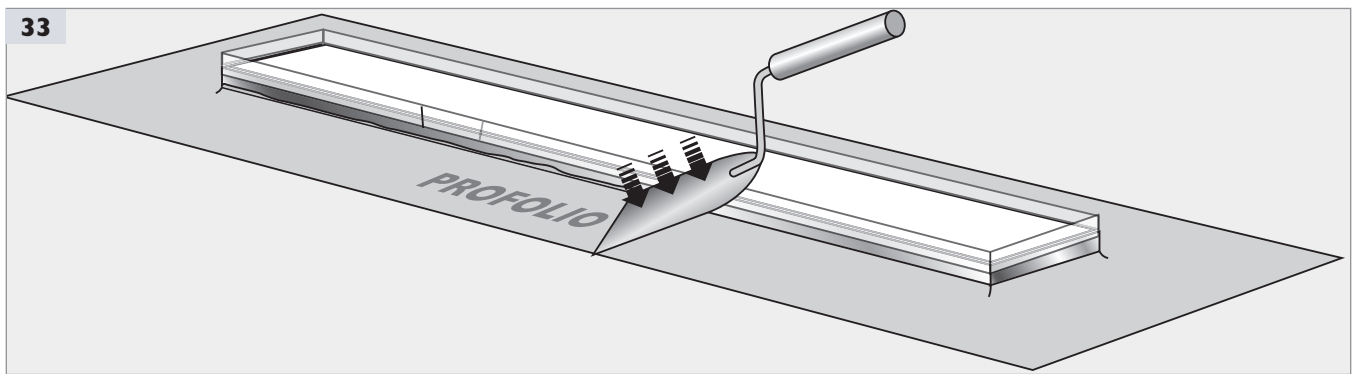
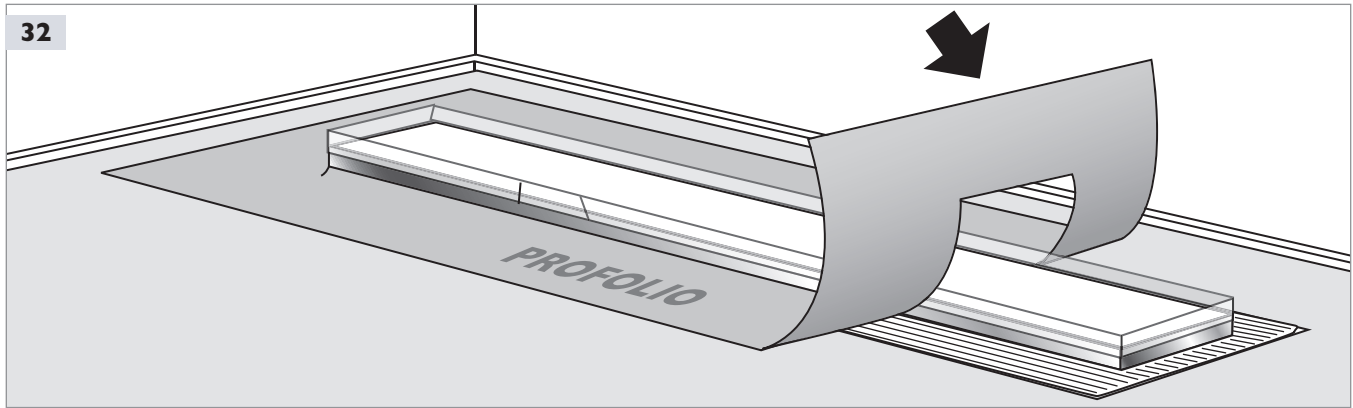

**Maße**

- GB dimensions    F dimensions    I misure  
E medidas    NL afmetingen    N måll

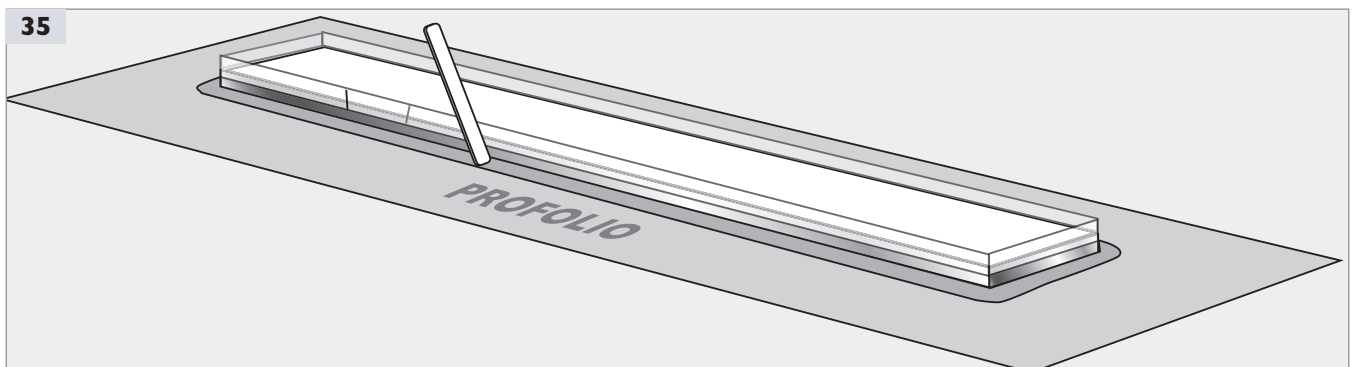

# PROCHANNELp-line

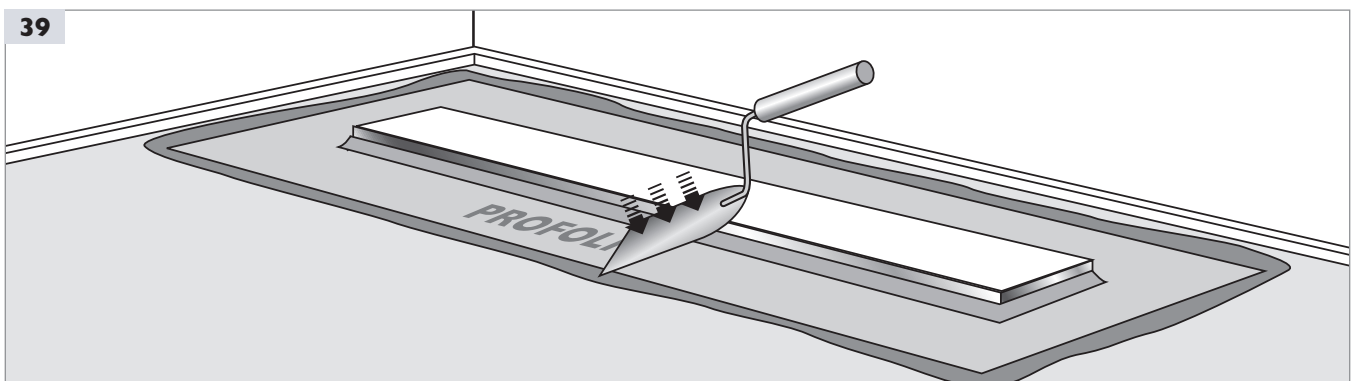
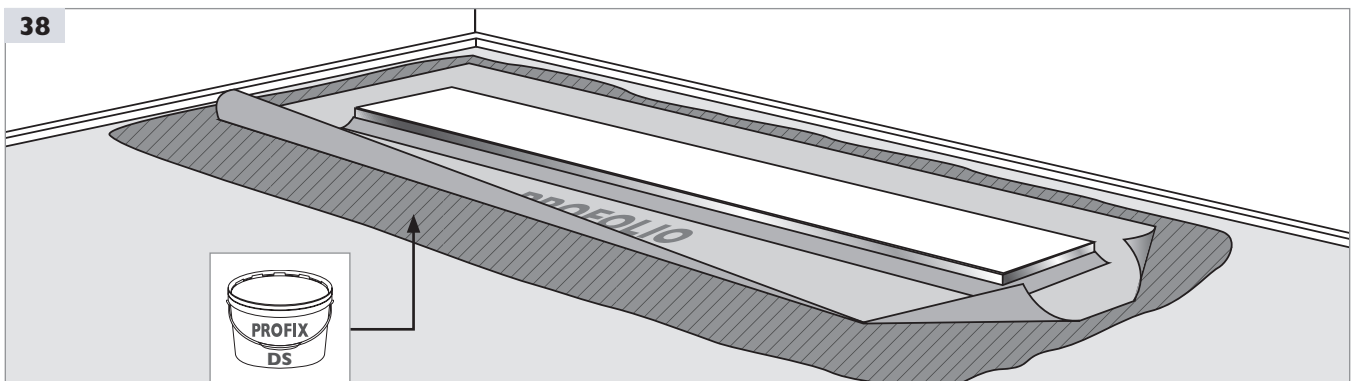
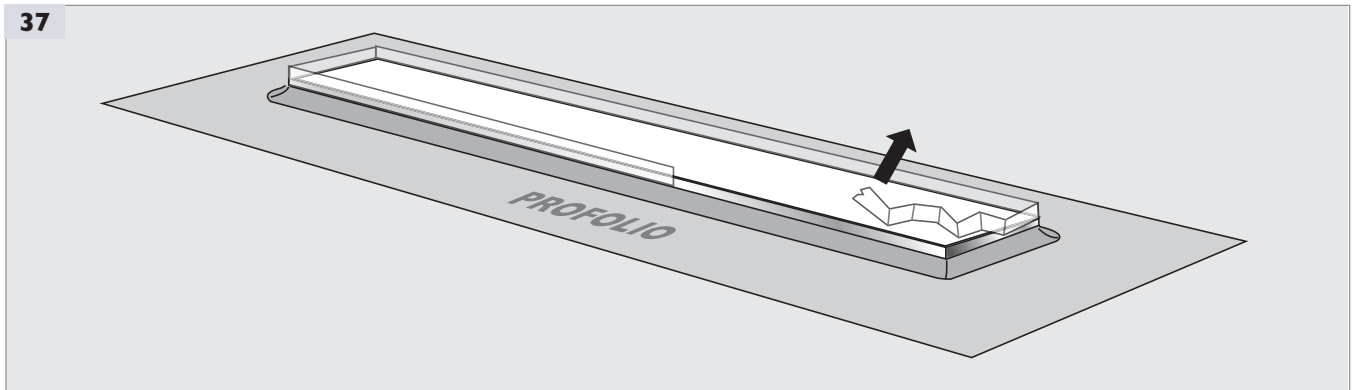
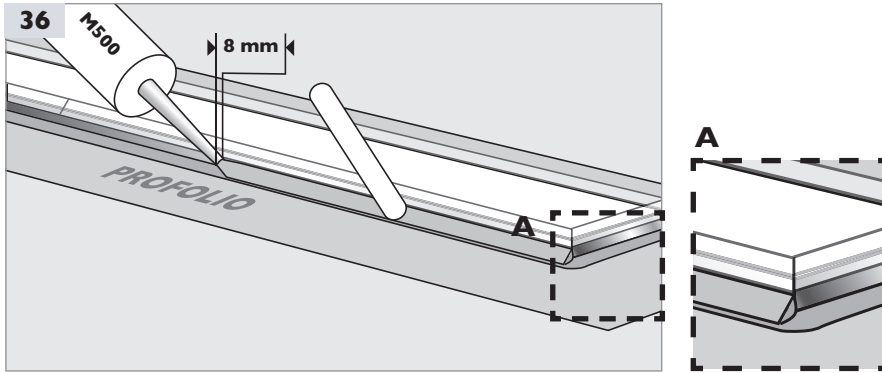

AUSGABE\_2014\_01\_LIZ\_AH

# PROCHANNELp-line

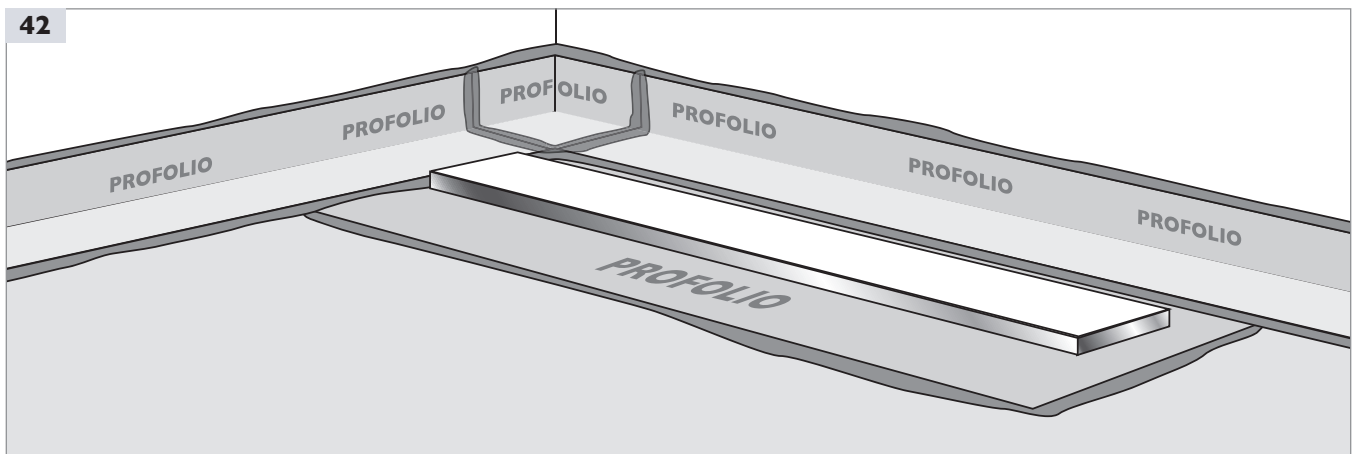
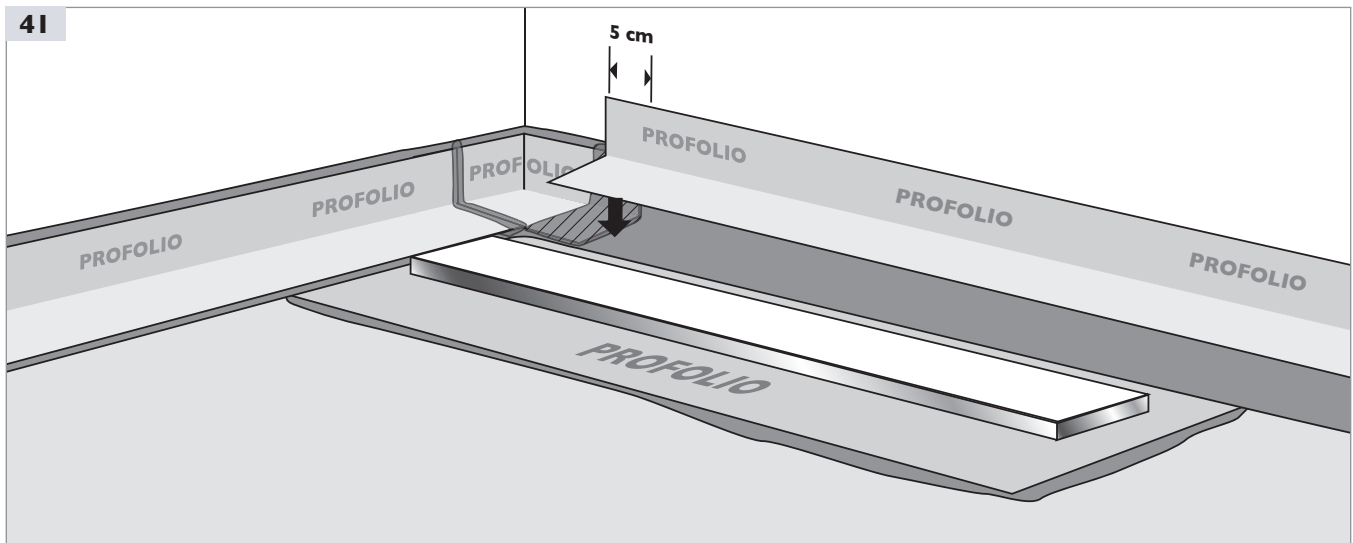
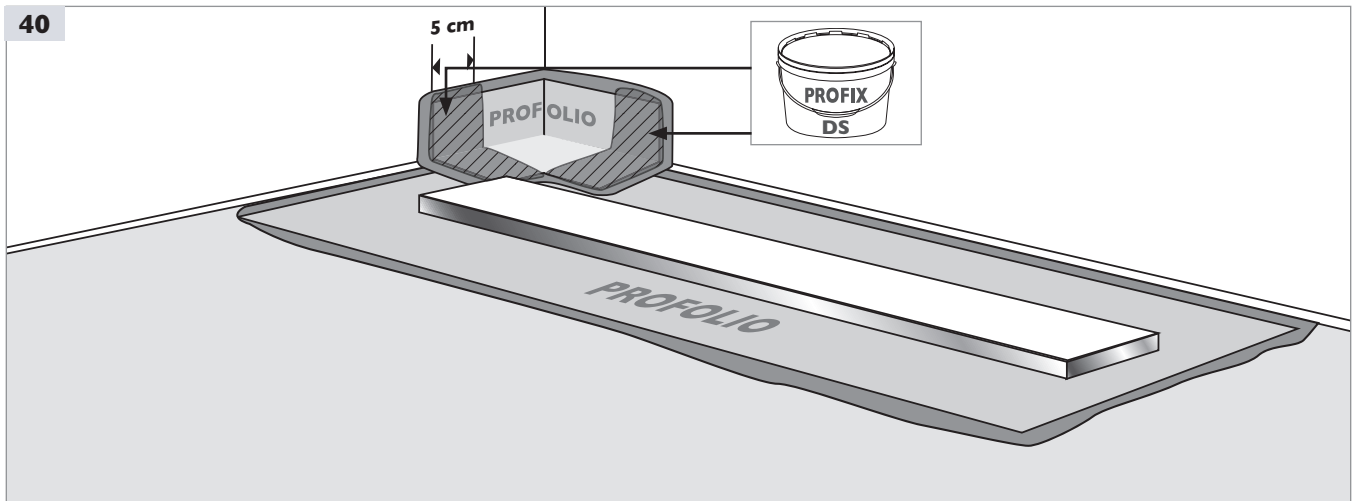

AUSGABE\_2014\_01\_LIZ\_AH

# PROCHANNELp-line

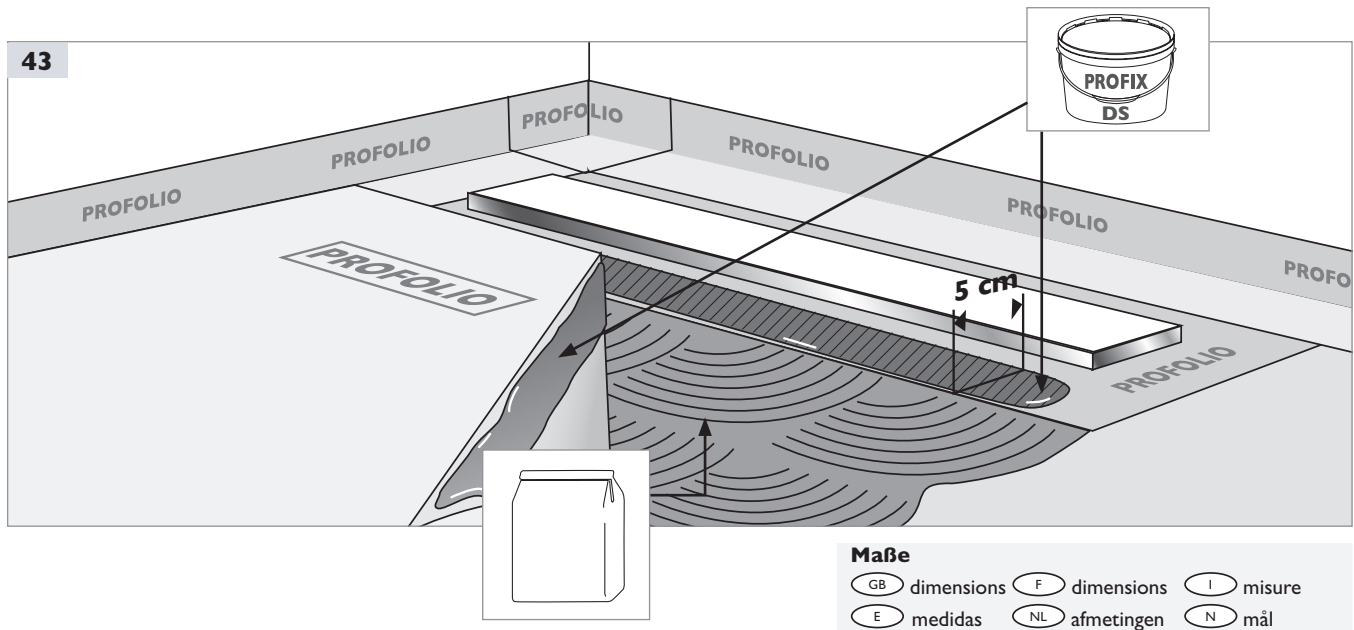

# PROCHANNELp-line

**D**

Alle Angaben, Verweise, Hinweise, zugrundegelegten Fachregeln, Regelwerke, Normen und Fachkenntnisse orientieren sich zuvor an den deutschen und soweit deckungsgleich an den vorhandenen europäischen Regelungen und Ausbildungsstandards, unabhängig zusätzlicher, länderspezifischer Erweiterungen oder Veränderungen. Alle unsere Angaben beruhen auf unseren Erfahrungen und sorgfältigen Untersuchungen. Die Vielfalt der mit verwendeten Materialien sowie die unterschiedlichen Baustellen- und erarbeitungsbedingungen können von uns jedoch nicht im Einzelnen überprüft oder beeinflusst werden. Die Erfüllung eines geschuldeten Werksvertrags und die Herstellung der nachweislichen Funktionstauglichkeit des Gewerkes ist deshalb abhängig von der Beachtung der aktuellen Regeln der VOB und der anerkannten Regeln der Technik. Unsere Angaben entbinden den verantwortlichen Planer und den Verarbeiter nicht von Ihrer Pflicht, die Objektbedingungen und Anwendbarkeit der Produkte eigenverantwortlich zu beurteilen. Im Zweifelsfall Eigenversuche durchführen oder anwendungstechnische Beratung einholen. Die Verlegerichtlinien der Belagshersteller sind zu beachten. Mit dem Erscheinen dieser Montageanleitung verlieren alle vorausgegangenen Montageanleitungen ihre Gültigkeit.

**GB**

All information, references, instructions, basic engineering principles, regulations, standards and expertise are based on German and largely equivalent European regulations and training standards, irrespective of additional country-specific supplements and amendments. All our specifications are based on our experience and careful analysis. We are unable to examine or influence the diversity of associated materials used and the various construction site and processing conditions in detail. Fulfilment of an imposed work order and verifiable functionality of the object therefore depends on the observation of current VOB rules and the recognised rules of technology. Our details do not absolve the accountable planner's and fitter's obligation to assess - on their own authority - the building conditions and practicability of the products. In case of doubt, carry out your own tests or seek technical application advice. Please refer to the laying and processing guidelines of the floor covering manufacturers or the manufacturers of associated products. All installation instruction previously published are superseded by this product data sheet once published.

**F**

Toutes les données, références, consignes, règles professionnelles, codes, normes et connaissances professionnelles s'orientent sur les réglementations allemandes et, si elles se recoupent, sur les réglementations européennes en vigueur et sur les standards de formation professionnelle en vigueur, indépendamment des compléments ou modifications propres à chaque pays. Toutes nos informations sont basées sur notre expérience et des enquêtes minutieuses. La variété des matériaux utilisés et les conditions différentes des chantiers et du traitement ne peuvent pas être contrôlées individuellement ou influencées en détail par nous. L'exécution d'un contrat d'entreprise devant être effectué et l'établissement du bon fonctionnement des travaux de construction dépendent donc du respect la réglementation allemande VOB actuelle et des règles techniques généralement reconnues. Nos informations ne dispensent pas le planificateur et le processeur responsables de l'obligation de vérifier par leurs propres moyens de contrôle les conditions d'objet et l'applicabilité des produits. En cas de doute, consulter des recommandations techniques pour l'utilisation ou procéder à des essais personnels. Les directives de pose et de traitement éditées par les fabricants de revêtements ou de produits annexes doivent être respectées. À la parution de cette notice de montage, toutes les autres notice de montage perdent leur validité.

**I**

Tutte le nostre indicazioni sono basate sulla nostra esperienza e su indagini accuratamente svolte. Non ci è possibile tuttavia verificare o influenzare singolarmente l'intera gamma dei materiali utilizzati né tutte le diverse condizioni di cantiere e di lavorazione. Pertanto la qualità e buona funzionalità del vostro lavoro dipenderà sempre dalla valutazione degli esperti del cantiere e dal vostro utilizzo dei prodotti. L'adempimento di una prestazione d'opera dovuta e l'attestazione dell'idoneità funzionale dell'opera sono pertanto subordinati al rispetto delle normative vigenti del VOB (regolamento tedesco sugli appalti) e delle regole tecniche riconosciute. Le nostre indicazioni non sollevano i progettisti e gli esecutori responsabili dell'opera dall'obbligo di giudicare sotto la propria responsabilità le condizioni degli oggetti e l'applicabilità dei prodotti. In caso di dubbi, seguire le avvertenze tecniche raccomandate oppure effettuare test propri. Attenersi alle linee guida di posa e la lavorazione fornite dai fabbricanti di tutti i prodotti utilizzati. In caso di dubbi eseguire controlli in proprio o richiedere una consulenza tecnica specifica. Osservare le linee guida di posa e lavorazione fornite dai produttori dei rivestimenti o degli altri prodotti utilizzati in concomitanza. Con la pubblicazione della presente documentazione tecnica decade la validità di tutte le precedenti versioni della documentazione stessa.

**E**

Todos nuestros datos se basan en nuestra experiencia y nuestros meticulosos análisis. Debido a la diversidad de los materiales empleados y a las múltiples condiciones de las obras y de tratamiento es imposible para nosotros controlar e influir sobre cada uno de ellos. Por tanto la calidad y función de su trabajo depende de su valoración técnica de la obra y del uso del producto. El cumplimiento exacto de un contrato de obra y la consecución de la funcionalidad demostrable de la obra depende, por tanto, del cumplimiento de las normas actuales del VOB (Ordenamiento de Adjudicación y Contratación para la Construcción) y del resto de normativas técnicas aplicables. Nuestros datos no eximen a los proyectistas responsables ni a los trabajadores encargados de su obligación de evaluar las condiciones del objeto y la aplicabilidad de los diferentes productos. En caso de duda, solicite asesoramiento sobre la aplicación técnica o realice sus propios ensayos. Es obligatorio el cumplimiento de las instrucciones de instalación y tratamiento especificadas por el fabricante del suelo, así como por los fabricantes del resto de productos utilizados. En caso de duda realice sus propios ensayos o solicite asesoramiento sobre la aplicación técnica. Es obligatorio el cumplimiento de las instrucciones de instalación y tratamiento especificadas por el fabricante del suelo, así como por los fabricantes del resto de productos utilizados. Con la publicación de esta hoja de datos pierden su validez las hojas de datos anteriores.



# PROCHANNELp-line

NL

Al onze specificaties zijn gebaseerd op onze ervaringen en zorgvuldige onderzoeken. Het grote aantal medegebruikte materialen en de verschillende bouwplaats- en verwerkingsomstandigheden kunnen door ons echter niet afzonderlijk worden beproefd of beïnvloed. De kwaliteit en het functioneren van uw werkzaamheden hangt daarom af van uw vakkundige bouwplaatsbeoordeling en uw toepassing van de producten. Daarom is de nakoming van een verschuldigd contract over de aanneming van het werk en het aantonen van het goed functioneren van de installatie afhankelijk van de naleving van de actuele regels van de VOB en de erkende regels van de techniek. Onze informatie ontslaat de verantwoordelijke planner en de verwerker niet van hun verplichting, de objectcondities en toepasbaarheid van de producten onder eigen verantwoordelijkheid te beoordelen. Bij twijfel moet gebruikstechnisch advies worden ingewonnen of eigen testen worden uitgevoerd. De leg- en verwerkingsrichtlijnen van de vloerbedekkingsfabrikanten resp. fabrikanten van medegebruikte producten moeten in acht worden genomen. In geval van twijfel eigen beproevingen uitvoeren of applicatietechnisch advies vragen. De leg- en verwerkingsrichtlijnen van de fabrikant resp. van de leverancier van medegebruikte producten moeten worden aangehouden. Met het verschijnen van dit productspecificatieblad verliezen alle voorgaande productspecificatiebladen hun geldigheid.

N

Alle informasjonene er basert på våre erfaringer og nøyaktige undersøkelser. Mangfoldet når det gjelder de tilleggsmaterialene som er benyttet og de ulike betingelsene på byggeplassene og andre steder materialene blir bearbeidet kan likevel ikke kontrolleres og påvirkes i hvert enkelt tilfelle. Ditt arbeids kvalitet og funksjon avhenger derfor av din egen faglige byggeplassvurdering og hvordan du bruker produktet. Overholdelsen av fabrikkkontrakten og opprettelsen av utstyrets beviselig funksjonsdyktighet er derfor avhengig av at man følger de aktuelle byggetekniske retningslinjene. Vår informasjoner medfører ikke at planleggere og den som håndterer materialet frigjøres fra plikten til å gjennomføre en selvstendig vurdering av objektbetingelsene og hvorvidt produktet kan benytte. I tilstilfeller må man innhente bruksteknisk anbefaling eller gjennomføre egne forsøk. Man må ta hensyn til retningslinjene for legging og bearbeidelse fra belegghprodusenten hhv. produsenten av andre produkter som benyttes. Hvis du er i tvil må du foreta egne forsøk eller innhente bruksteknisk rådgivning. Man må følge retningslinjene for legging og bearbeidelse som er gitt av belegghprodusenten eller produsenten av tilleggsproduktene. Utgivelsen av dette produktdatabladet tilsier at tidligere produktdatablader ikke lenger er gyldige.